

REVISION RECORD			
REV.	CONTENT	MOD.	DATE
△	初版发行		

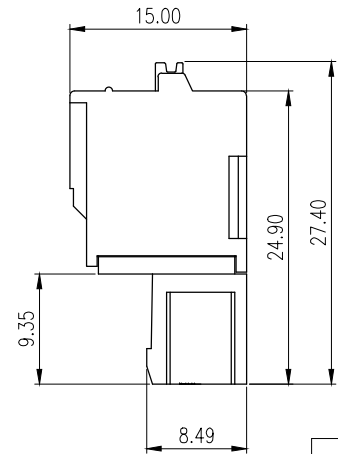
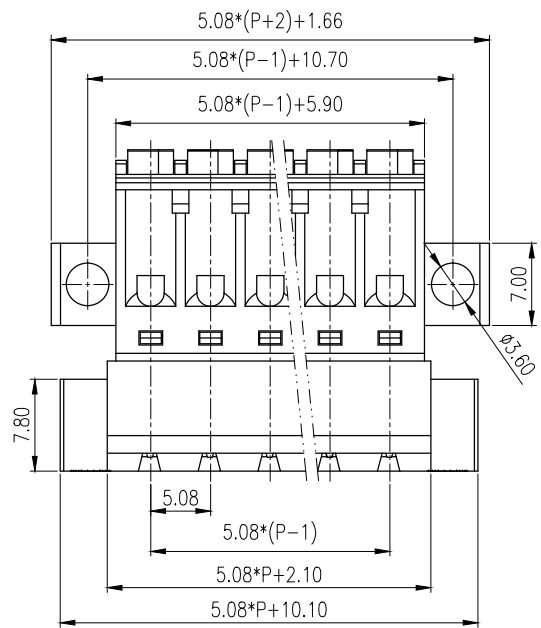
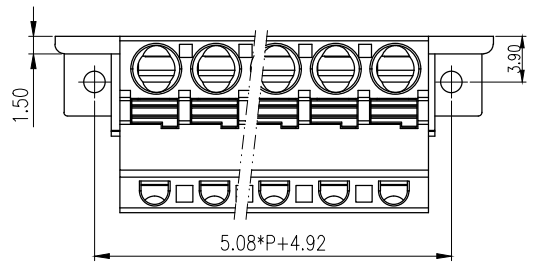

NOTES1:
UL Standard:
1.Voltage Rating: 300V, Current Rating: 10A

NOTES2:
1.Pitch : 5.08mm
2.Withstand Voltage : AC2500V for 1 minute
3.Using Temperature Range : -40℃ ~ +105℃
4.Suitable Electric Wire: 26-12AWG

技术要求1:
UL 标准:
1. 额定电压: 300V, 额定电流: 10A

技术要求2:
1. 间距: 5.08mm
2. 耐电压值: AC2500V/min
3. 使用条件: -40℃~+105℃
4. 适用线规: 26~12AWG

6	LZ1-耳朵螺母	SM00B25000V	2	黄铜		
5	LC60-5.08五金件	2083B0001AV	P	磷青铜	镀亮锡	
4	LC6-5.08-弹片	F2A0DLC658BV	P	不锈钢		
3	LC6-5.08-按钮	1020D0Y01AV	P	POM		
2	LC60MG-5.08-盖板	2083N0YXXAV	1	PA66-V0		
1	LC60N-5.08-本体	2084A0YXXAV	1	PA66-V0		
NO.	NAME OF PART		NO. OF PART	Q' TY	MATERIAL	NOTES
DES.	CMZ	DATE	2025/03/26	UNITS	MM	THIRD ANGLE PROJECTION
CHK.		DATE		SIZE	A4	1 of 1
APP.		DATE		SCALE	1:1	REV: V0
 上海有乐电气有限公司 Shanghai YouLe Electric C O.,LTD					TITLE	LC60NMG-5.08-XXP-1Y-00A
						LC60NMG-5.08-成品

	pitch dimension			Nominal dimension					— ◇ ○
	over 0	over 6	over 10	over 0	over 30	over 60	over 100	over 150	
variable range	to 6	to 10	to 24	to 30	to 60	to 100	to 150		
Tolerance	±0.1	±0.15	±0.25	±0.2	±0.3	±0.5	±0.7	±1.0	0.05/10